

Proclaim™

Use and Care Instructions For Your Proclaim Custom-Jet Oral Health System



www.proclaimhealth.com

Important safeguards

Save these instructions



Read all instructions before use.

This product is intended for household use. When using electrical products, especially when children are present, basic safety precautions should always be followed, including the following:

Danger:

To reduce the risk of electrocution:

- Do not handle plug with wet hands.
- Do not place or drop into water or other liquid.
- Do not use while bathing.
- Do not place or store product where it can fall or be pulled into a tub or sink.
- Do not reach for a product that has fallen into water. Unplug immediately.
- Check the power supply cord for damage before the first use and during the life of the product.

Warning:

To reduce the risk of burns, electrocution, fire, or injury to persons:

- Do not plug this device into a voltage system that is different from the voltage system specified for the device. This product is designed to operate within a range of 110 to 220 volts. Use with improper voltage will damage the product and void the warranty.
- Do not operate this product outside of a temperature range of 10–40 degrees Celsius.
- If the product is opened/disassembled for ANY reason, then the warranty is void.

- Do not use this product if it has a damaged cord or plug, if it is not working properly, if it has been dropped or damaged, or dropped into water. Contact Proclaim at 1-888-576-3756 or visit proclaimhealth.com.
- Use this product only as indicated in these instructions. Do not use the product on other parts of the body not specified.
- Use only accessories recommended by Proclaim.
- Do not insert any foreign object into any opening of the product, including the reservoir, handle, or hydro line.
- Keep electrical cord away from heated surfaces.
- Do not use any liquids or oils in the reservoir other than what is indicated in these instructions. Using unapproved additives will void the product warranty. Fill the reservoir with water or other Proclaim recommended solutions only.
- Remove any oral jewelry prior to use of the Proclaim system.
- Do not use the Proclaim system if you have an open wound or other injury in your mouth. Consult your dental professional before using Proclaim if you have had oral or gum surgery/procedures recently.
- If your physician or cardiologist has advised you to receive antibiotic premedication before dental procedures, you should consult your dentist and/or medical professional before using Proclaim.
- Do not use Proclaim continuously for more than 3 cycles, without at least 1 minute in between. Continuous usage can permanently damage the device.
- Using abrasive or chemical cleaners may damage the plastic housing of this product.
- Persons (including children) with reduced physical, sensory, or mental capabilities, or lack of experience and knowledge, should only use this product after they have been given supervision or instruction concerning use of the product by a person responsible for their safety.
- Children should be supervised to ensure that they do not play with the appliance.

Table of Contents

- 4** Product Description
- 5** Mouthpiece Fit Check
- 6** First Time Setup
- 8** Prepare For Treatment
- 10** Your 7-Second Treatment
- 11** After Your Treatment Cycle
- 12** Care And Maintenance
- 14** Troubleshooting Guide
- 20** Limited One-Year Warranty

Get To Know Your Proclaim Custom-Jet Oral Health System

For videos and other instructions, visit www.proclaimhealth.com/instructions

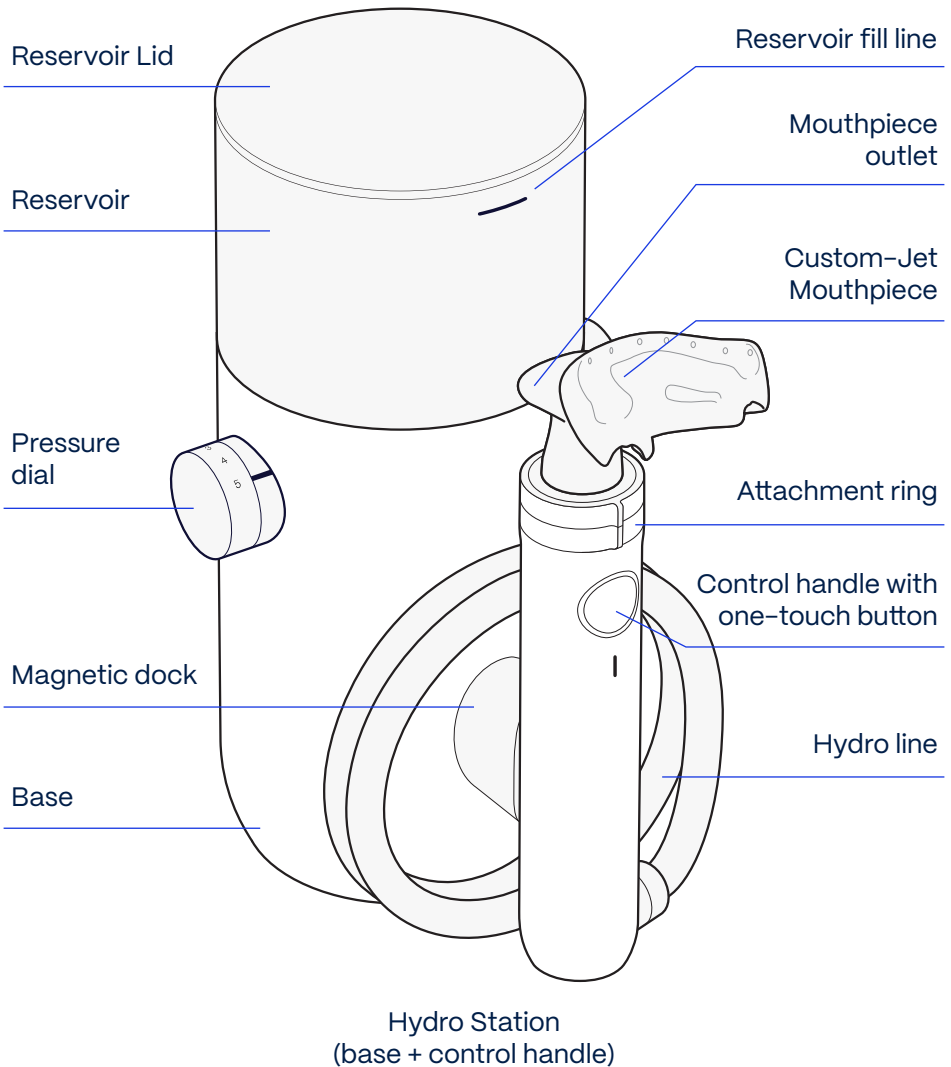

Mouthpiece Fit Check

Your mouthpiece is customized based on the digital scan of your mouth. To check it fits correctly, please follow these steps:

- 1 Place your mouthpiece in your mouth. It may be helpful to wet it first, and place it into your mouth one side at a time.
- 2 Bite down firmly, but without clenching. It can be subtle, but your molars should “slot” into position – there should be one position for your teeth that feels right.
- 3 Make sure you can keep your mouthpiece in place without significant movement/wiggling.

NOTE: Your mouthpiece will not fit tightly against your teeth or cover them completely, nor will all of your teeth touch it.

First Time Setup

- 1 Unpack the system and plug the Hydro Station into the outlet. Do NOT attach the Custom-Jet Mouthpiece yet.

NOTE: Handle your mouthpiece with care. It was created with customized technology and may be damaged if dropped. If dropped, inspect for damage. Always store the mouthpiece in its case to protect it.

NOTE: You have received several colored mouthpiece identification bands with your mouthpiece. If you have multiple people in your household using Proclaim, you can use these bands to easily distinguish your mouthpieces. They can be stretched and placed around the neck of the mouthpiece, just above the attachment ring.

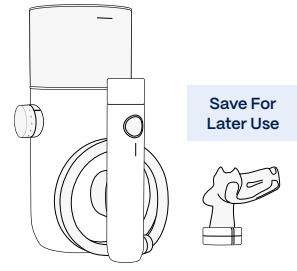

- 2 Remove the reservoir, fill it with **warm water** up to the fill line, and replace it on the base. Make sure the reservoir is fully seated and flush with the base.

Always fill the reservoir up to the fill line. One cycle will use the entire reservoir of water.

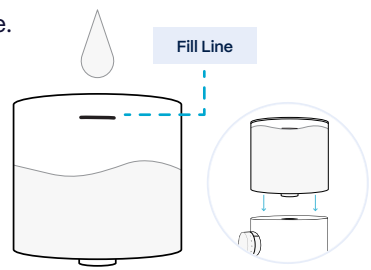

- 3 Set the pressure dial to **Level 1**.

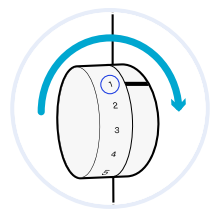

- 4 Remove the handle from the magnetic dock. Be careful not to accidentally push the button too early.

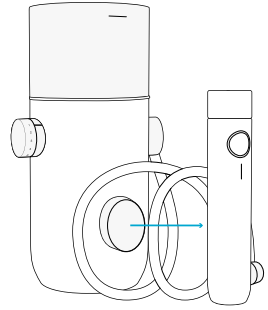

Save The Protective Handle Cap For Future Use

- 5 Remove the protective handle cap. You can save this and use it to cover the handle in between treatments.

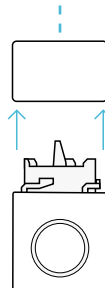

- 6 Point the end of the handle into the sink. Then press and hold the button until the cycle ends automatically.

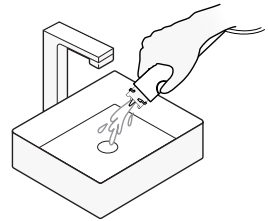

- 7 Replace the handle on the magnetic dock.

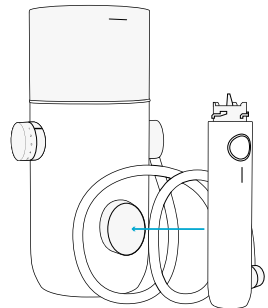

Prepare for Treatment

Fill The Reservoir And Add Proclaim Oral Infusion

- 1 Fill the reservoir with **warm water** and place it back on the base. Make sure the reservoir is fully seated and flush with the base.

Always fill the reservoir up to the fill line. One treatment will use the entire reservoir of water.

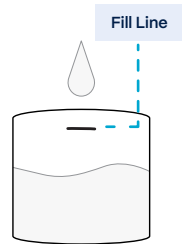

Reservoir Should Be Flush With The Base

- 2 For the most refreshing experience, add 20ml of the Proclaim Oral Infusion Concentrate to the water in the reservoir, using the included measuring cup.

The Proclaim Oral Infusion Concentrate has been specially developed for use in the Proclaim Custom-Jet Oral Health System. Other additives should not be added to the system. Other additives may damage the device and will void the product warranty.

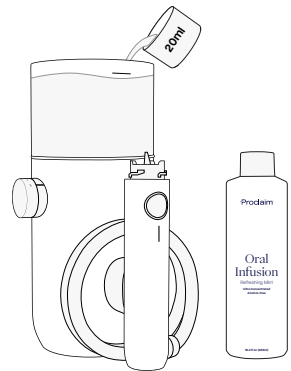

Set the Pressure

- 1 Use the dial to set the pressure level of your treatment. Start at level 1 for your first treatment as you acclimate to the system. Increase your pressure level over time until you feel comfortable with level 5 (the recommended setting).

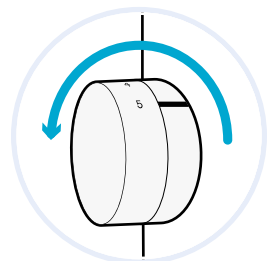

Attach Your Custom-Jet Mouthpiece

- 1 Remove the handle from the magnetic dock.

Take care not to accidentally push the button.

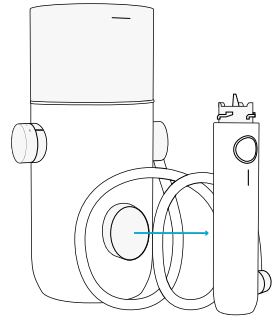

- 2 Place your mouthpiece on the handle, positioning it so the bite surface is facing forward (aligned with the button). The tab on the attachment ring should be in the "open" position – a bit to the right of the button.

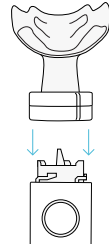

- 3 Twist the attachment ring clockwise until it clicks and the tab is centered, indicating that the mouthpiece is securely attached.

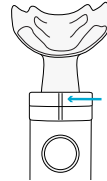

Attachment Ring
Should Click

Your 7-Second Treatment

Position your Mouthpiece

- 1 To make it easier to insert, wet your mouthpiece with water before inserting it. It can also be helpful to insert one side of the mouthpiece and then the other.



- 2 Place your mouthpiece in your mouth and seal your lips around it. Getting a good seal with your lips will prevent water from dribbling out and making a mess during treatment (the water will drain neatly out through the mouthpiece outlet).



- 3 Bite down securely without clenching – the mouthpiece material is hard and it may take a moment to adjust to the way it feels. The material enables precise targeting and effective water pressure.

Run The Treatment Cycle

- 1 Lean over the sink. This way the liquid will drain out of the mouthpiece outlet into the sink.
- 2 Press and **hold the button on the control handle until the treatment is complete – it will stop automatically.** If you release the button early, the treatment will stop.

NOTE: At Level 5, the treatment will last about 7 seconds. At lower pressure settings, the treatment will last longer (up to about 25 seconds). The entire reservoir will be used in one treatment at all settings.

- 3 Remove your mouthpiece from your mouth while still leaning over the sink, so any excess water drains into the sink.



After Your Treatment Cycle

- 1 Detach your mouthpiece by twisting the attachment ring counterclockwise.
- 2 Rinse your mouthpiece under running water.

Make sure to store it in the provided case, as it is precision technology and should be treated with care.

Minimize exposure to heat, light, or other potentially damaging elements.

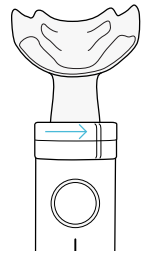

- 3 Replace the handle on the magnetic dock.

NOTE: You can use the protective handle cap to cover the handle in between treatments if you'd like.

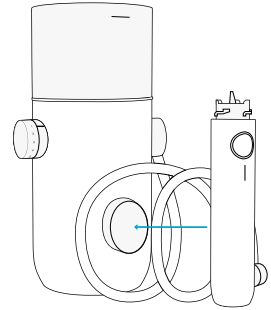

- 4 If you used the Proclaim Oral Infusion concentrate, rinse the reservoir between uses.

NOTE: If Oral Infusion residue is left in the reservoir, filling it with water before the next treatment may produce bubbles or foam in the reservoir, which can make it more difficult to fill the reservoir fully.

Care and Maintenance

Hydro Station

- Unplug the Hydro Station and wipe external surfaces with a soft wet cloth along with mild soap.
- The water reservoir and lid can be washed in warm soapy water or in the top rack of the dishwasher.
- Once a month, fill the reservoir $\frac{1}{3}$ to $\frac{1}{2}$ full with distilled white vinegar (4–6% acidity), then add warm water to the fill line. Run a cycle with no mouthpiece attached (on level 1 to minimize splashing), then repeat with a reservoir of fresh water.
- If the Hydro Station has not been used for a few weeks, run a vinegar cleaning cycle as per the above instructions.

- Do not submerge the Hydro Station in water or place it in the dishwasher (except for the water reservoir and lid).
- Do not clean the base under running water.
- Do not use abrasive pads/sponges, corrosive cleaning agents, or cleaning agents containing bleach.
- Do not run a cycle with very hot or boiling water.

Custom-Jet Mouthpiece

- Rinse the mouthpiece under the tap after each use. Store it in the provided case to protect it and to minimize exposure to heat, light, or other potentially damaging elements.
- You can wipe the area where teeth and lips are placed with a soft wet cloth if needed (for example, to remove lipstick).
- Once a month, fully submerge your mouthpiece in distilled white vinegar (4–6% acidity) for 30 minutes. Use the vinegar as-is – do not add water. After soaking, rinse your mouthpiece thoroughly under running tap water, making sure to direct the water flow into the holes in the base of the mouthpiece, and then shake it a few times to remove the excess water.
- The storage case for the mouthpiece can be washed in warm soapy water or in the top rack of the dishwasher.

- Do not clean the mouthpiece in the dishwasher.
- Do not soak it in very hot or boiling water, or use any solution containing alcohol or bleach.
- Do not use abrasive pads/sponges or corrosive cleaning agents.
- Do not use anything that leaves debris as this could potentially block the precision jets and affect the mouthpiece performance.
- Do not leave your mouthpiece exposed to UV light. This may cause yellowing and discoloration.
- Do not leave your mouthpiece in the car, in sunlight, outdoors, or in other places where it may be damaged due to extreme temperatures. Always place your mouthpiece in the provided mouthpiece case when not in use and store in a room temperature environment.

Troubleshooting Guide

Problem	What to do
My mouthpiece doesn't fit	<p>Try wetting the mouthpiece first, and then inserting one side into your mouth and then the other side</p> <p>Your mouthpiece will not fit like a night guard or retainer, and may take some getting used to if you are accustomed to other products. It may feel a bit bulky, and the material may feel harder than you expect. It will not fit tightly against your teeth, as the water needs room to flow. You can check out a video on how the mouthpiece should fit on our instructions page: www.proclaimhealth.com/instructions</p> <p>If your oral anatomy has changed since your scan, your mouthpiece may not fit as well, and you may need to get a new scan and mouthpiece.</p> <p>If you still feel that your mouthpiece doesn't fit, please contact Proclaim Customer Care.</p>
My mouthpiece doesn't reach my gumline or cover my teeth completely	<p>The mouthpiece will not always reach to your gumline or cover all of your teeth fully – the jets are often angled so they can reach beyond the mouthpiece itself which helps to prevent the mouthpiece from getting too big.</p>
My front teeth don't touch the mouthpiece	<p>In most mouthpieces, it is expected that your front teeth do not touch the mouthpiece, and that only some of your molars will contact the biting surface of the mouthpiece and "slot" into position. This is sufficient to keep the mouthpiece in the right place.</p>
I dropped my mouthpiece / my mouthpiece is broken	<p>Your mouthpiece may be damaged if dropped. If dropped, inspect for damage. If you see cracks or chips, do not use it and contact Proclaim Customer Care.</p>

Problem

What to do

I can't attach my mouthpiece

Check out the instruction video on how to set up your Proclaim system on our instructions page: www.proclaimhealth.com/instructions
If you are still facing issues, contact Proclaim Customer Care.

The Proclaim treatment feels uncomfortable

Some temporary or mild discomfort may occur when first using your Proclaim system, as you get acclimated to the feeling of the mouthpiece and sensation of water pulsing between teeth and below the gumline, and as any gum inflammation starts to subside.

Make sure you start treatment at Level 1, and gradually increase the pressure to Level 5 as you acclimate to how it feels.

Make sure you are using warm water, as cold water can be uncomfortable.

Should you experience any of the following, please discontinue use and contact the Proclaim Customer Care team or your dental professional:

- Severe pain
- Severe sensitivity
- Bleeding that is persistent or more than you would experience using dental floss
- Cuts, abrasions, or discomfort along your gums
- Any unusual pain after using the product that is not temporary

Problem**What to do**

There's a shock of cold water when I start a Proclaim treatment

It is normal that a bit of water will be left in the tubes after a treatment, and this room-temperature water will be felt at the beginning of the next treatment. If this bothers you, you can flush a bit of warm water through the system before your treatment. Just add some warm water to the reservoir, point the handle into the sink (with no mouthpiece attached), and press the button for a couple seconds. Make sure to fill the reservoir fully to the fill line (and add your oral infusion, if using) before starting your actual treatment.

The LED in the handle turned red

If the LED is red, try unplugging your Hydro Station for 10 seconds and then plugging it back in.

Check the filter basket that is underneath where the water reservoir slots into the base to make sure it is not clogged.

If the red LED persists, please contact Proclaim Customer Care.

I pushed the button but nothing happened

Make sure your Hydro Station is plugged into an active outlet, and that the GFCI circuit breaker of the outlet hasn't tripped. If it is, try unplugging it for 10 seconds and then plugging it back in.

Make sure you have removed the handle from the magnetic dock, as you cannot run a cycle while it is docked.

If pushing the button still does not start a cycle, please contact Proclaim Customer Care.

Problem

What to do

The water reservoir doesn't sit flat on the base / there is a small gap between the reservoir and the base

Make sure the reservoir has slotted into position. After you align the reservoir outlet with the inlet on the top of the base, there is a small feature on the back side of the reservoir that allows it to slot into position on the base – this prevents the reservoir from rotating on the base.

It is normal if there is a small gap between the reservoir and the base when you place the empty reservoir, or at the end of a treatment when the reservoir is (mostly) empty. This gap does not affect the operation of the product.

If there is a gap between the reservoir and the base when the reservoir is full and properly aligned on the base, please contact Customer Care.

The water reservoir is leaking

If water consistently drips out of the valve in the bottom of the reservoir, try pushing it up and down a few times with your finger and check that no debris is stuck in it.

If leaking continues, it could be a sign of a damaged valve. Please contact Proclaim Customer Care for a replacement.

There is water left in the water reservoir after my treatment

It is normal that a small amount of water is left in the reservoir after treatment. Make sure you are filling the reservoir to the fill line, but not above it, to minimize this. If you use your Proclaim system regularly, this should not be a problem. If it bothers you, you can remove the reservoir and pour the excess water into the sink after use.

Problem

What to do

The water reservoir is hard to remove from the base

If there is still too much water left in the reservoir after the treatment is complete (for example, if you filled the reservoir above the fill line), then it can make the reservoir a bit difficult to remove. Try angling the reservoir towards the front while you are removing it (instead of trying to pull it straight up).

If that doesn't work, point the handle (without the mouthpiece attached) into the sink and press the button for 1-2 seconds to run most of the water out of the reservoir.

My Hydro Station is leaking/damaged

If you are experiencing leaking during treatment from the area where the mouthpiece attaches to the handle, make sure your mouthpiece is fully attached, and that the attachment ring has clicked into the closed position.

Make sure that the round gray seal at the top of the handle is present. If it is missing, contact Proclaim Customer Care.

If you experience leaking from the Hydro line or the base, or if you observe significant damage to the Hydro line or base, discontinue use and unplug the Hydro Station immediately. Contact Proclaim Customer Care for further instructions.

Other Damage to the Unit

If any damage to the unit occurs, discontinue use immediately and unplug the system from the electrical outlet. Proclaim does not sell replacement parts and does not recommend self-service of your Proclaim system. Do not attempt to open or modify your Proclaim system. Contact Proclaim Customer Care for assistance.

Locating your serial numbers

If you need to contact Proclaim Customer Care, you may be asked for your Hydro Station and/or mouthpiece serial number.

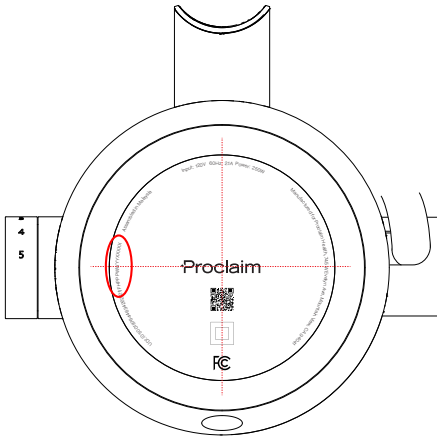

The Hydro Station serial number can be found on the underside of the base, starting with the digits "(21)FH..."



The 6 digit Mouthpiece serial number can be found on the vertical neck of the mouthpiece, underneath the outlet and above the attachment ring. It may be a bit difficult to see – shining a flashlight on it can help.

For FAQs and other helpful information, see our online help center: <https://help.proclaimhealth.com>.

Proclaim is not engaged in rendering medical, dental, or similar professional services or advice, and the information provided on our website or in these Instructions for Use are not intended to replace medical or dental advice offered by a healthcare provider. If you desire or need such services or advice, you should promptly consult a dentist or other professional health care provider. You should not use the information contained herein for diagnosing a health or dental problem or disease. You should always consult with a dentist or other health care professional for medical or dental advice -- or information about diagnosis and treatment.

One year product warranty

LIMITED PRODUCT WARRANTY.

THIS LIMITED WARRANTY GIVES YOU SPECIFIC LEGAL RIGHTS AND YOU MAY ALSO HAVE OTHER RIGHTS, WHICH VARY FROM STATE TO STATE.

WE WARRANT THAT DURING THE WARRANTY PERIOD, THE PRODUCTS (BEING ANY DEVICES, HYDROSTATIONS, MOUTHPIECES, OR OTHER PRODUCTS) PURCHASED FROM THE SITE WILL BE FREE FROM DEFECTS IN MATERIALS AND WORKMANSHIP.

WE LIMIT THE DURATION AND REMEDIES OF ALL IMPLIED WARRANTIES, INCLUDING WITHOUT LIMITATION THE WARRANTIES OF MERCHANTABILITY AND FITNESS FOR A PARTICULAR PURPOSE, TO THE DURATION OF THIS LIMITED WARRANTY.

SOME STATES DO NOT ALLOW LIMITATIONS ON HOW LONG AN IMPLIED WARRANTY LASTS, SO THE ABOVE LIMITATION MAY NOT APPLY TO YOU.

OUR RESPONSIBILITY FOR DEFECTIVE PRODUCTS IS LIMITED TO REPAIR, REPLACEMENT OR REFUND AS SET FORTH IN THIS WARRANTY STATEMENT. NEITHER ANY PERFORMANCE OR OTHER CONDUCT, NOR ANY ORAL OR WRITTEN INFORMATION, STATEMENT OR ADVICE PROVIDED BY US OR ANY OF OUR AGENTS OR EMPLOYEES WILL CREATE A WARRANTY, OR IN ANY WAY INCREASE THE SCOPE OR DURATION OF THIS LIMITED WARRANTY.

Who May Use This Warranty?

This limited warranty extends only to the original purchaser of products from the Site. It does not extend to any subsequent or other owner or transferee of the product or any transferee.

What Does This Warranty Cover?

This limited warranty covers during the Warranty Period (as defined below) defects in materials and workmanship in products purchased from the Site.

What Does This Warranty Not Cover?

This limited warranty does not cover any damages due to:

- Transportation
- Storage
- Improper use
- Failure to follow the product instructions or to perform any preventive cleaning or maintenance
- Modifications
- Combination or use with any products, materials, processes, systems or other matter not provided or authorized in writing Fresh Health
- Unauthorized repair
- Cosmetic issues that do not affect the function of the product
- Discoloration of the mouthpiece for any reason, including exposure to bright light or sunlight
- Normal wear and tear
- External causes such as accidents, abuse, or other actions or events beyond our reasonable control.

What is the Period of Coverage?

This limited warranty starts on the initial date of delivery and lasts for one year the "Warranty Period". The Warranty Period is not extended if we repair or replace a warranted product or re-perform a warranted service. We may change the availability of this limited warranty at our discretion, but any changes will not be retroactive.

What Are Your Remedies Under This Warranty?

With respect to any defective products during the Warranty Period, we will, in our sole discretion, either: (i) repair or replace such products (or the defective part) free of charge or (ii) refund the purchase price of such products. We will also pay for shipping and handling fees to return the repaired or replacement product to you if we elect to repair or replace the defective products.

How Do You Obtain Warranty Service?

To obtain warranty service, you must call 888-576-3756 or email our Customer Care Team at customercare@proclaimhealth.com during the Warranty Period to obtain an RMA number. No warranty service will be provided without an RMA number.

Limitation of Liability

THE REMEDIES DESCRIBED ABOVE ARE YOUR SOLE AND EXCLUSIVE REMEDIES AND OUR ENTIRE OBLIGATION AND LIABILITY FOR ANY BREACH OF THIS LIMITED WARRANTY. OUR LIABILITY WILL UNDER NO CIRCUMSTANCES EXCEED THE ACTUAL AMOUNT PAID BY YOU FOR THE DEFECTIVE PRODUCT OR SERVICE THAT YOU HAVE PURCHASED THROUGH THE SITE, NOR WILL WE UNDER ANY CIRCUMSTANCES BE LIABLE FOR ANY LOSS OF PRODUCTION, WORK, DATA, USE, BUSINESS, GOODWILL, REPUTATION, REVENUE OR PROFIT, ANY DIMINUTION IN VALUE, COSTS OF REPLACEMENT GOODS OR SERVICES, OR ANY CONSEQUENTIAL, INCIDENTAL, SPECIAL OR PUNITIVE DAMAGES OR LOSSES, WHETHER DIRECT OR INDIRECT.

SOME STATES DO NOT ALLOW THE EXCLUSION OR LIMITATION OF INCIDENTAL OR CONSEQUENTIAL DAMAGES, SO THE ABOVE LIMITATION OR EXCLUSION MAY NOT APPLY TO YOU.

For USA Only

This device complies with part 15 of the FCC Rules. Operation is subject to the following two conditions: (1) This device may not cause harmful interference, and (2) this device must accept any interference received, including interference that may cause undesired operation. Warning: changes or modifications not expressly approved by the party responsible for compliance could void the user's authority to operate the equipment.

NOTE: This equipment has been tested and found to comply with the limits for a Class B digital device, pursuant to part 15 of the FCC Rules. These limits are designed to provide reasonable protection against harmful interference in a residential installation. This equipment generates, uses and can radiate radio frequency energy and, if not installed and used in accordance with the instructions, may cause harmful interference to radio communications. However, there is no guarantee that interference will not occur in a particular installation. If this equipment does cause harmful interference to radio or television reception, which can be determined by turning the equipment off and on, the user is encouraged to try to correct the interference by one or more of the following measures:

- Reorient or relocate the receiving antenna.
- Increase the separation between the equipment and receiver.
- Connect the equipment into an outlet on a circuit different from that to which the receiver is connected to.
- Consult the dealer or an experienced radio/TV technician for help.

Limitation of Liability

This limited warranty is your sole remedy against Fresh Health Inc. and it shall not be liable for any damages, whether direct, indirect, incidental, special, consequential, exemplary or otherwise, including but not limited to property damage, arising out of any theory of recovery, including statutory, contract or tort.